



Table of Contents

MOUNTING

Wall Mount Installation.....	Page 2
Double Mount Installation	Page 3

WIRING AND JUMPERS

Wiring Information and Jumper Settings.....	Page 4
---	--------

FREQUENTLY ASKED QUESTIONS

Wireless Digital Clock Frequently Asked Questions.....	Page 5
--	--------

TROUBLESHOOTING

Wireless Digital Clock Troubleshooting.....	Page 6
---	--------

FCC INFORMATION

FCC Wants You To Know.....	Page 7
----------------------------	--------

Wall Mount Installation

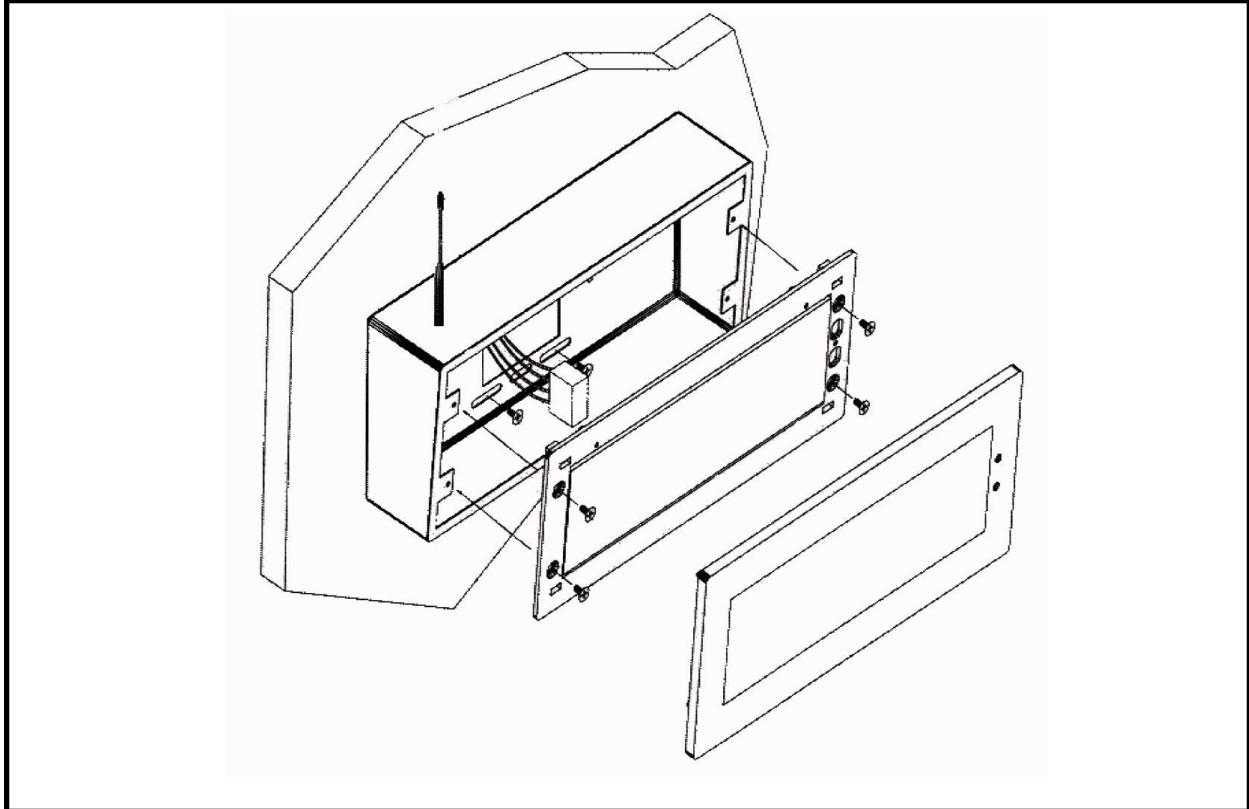

Instructions

1. Mount the wall mount box into the double gang box using four machine screws (#6-32) including in the kit.
2. Connect ground wire into flush mount box using tooth lockwasher and machine screw nut (included in the kit).
3. Disconnect the red filter from the display panel.
4. Connect the wiring as shown on the wiring diagram.
5. **IMPORTANT:** If using a low voltage system (24 volt) make sure that the transformer is an **isolated** transformer.
6. Mount the display panel into the flush mount box using four (4) black machine screws (#6, included in the kit). Make sure the switches are on the right side.
7. Snap the red filter into the display panel.

Double Mount Installation

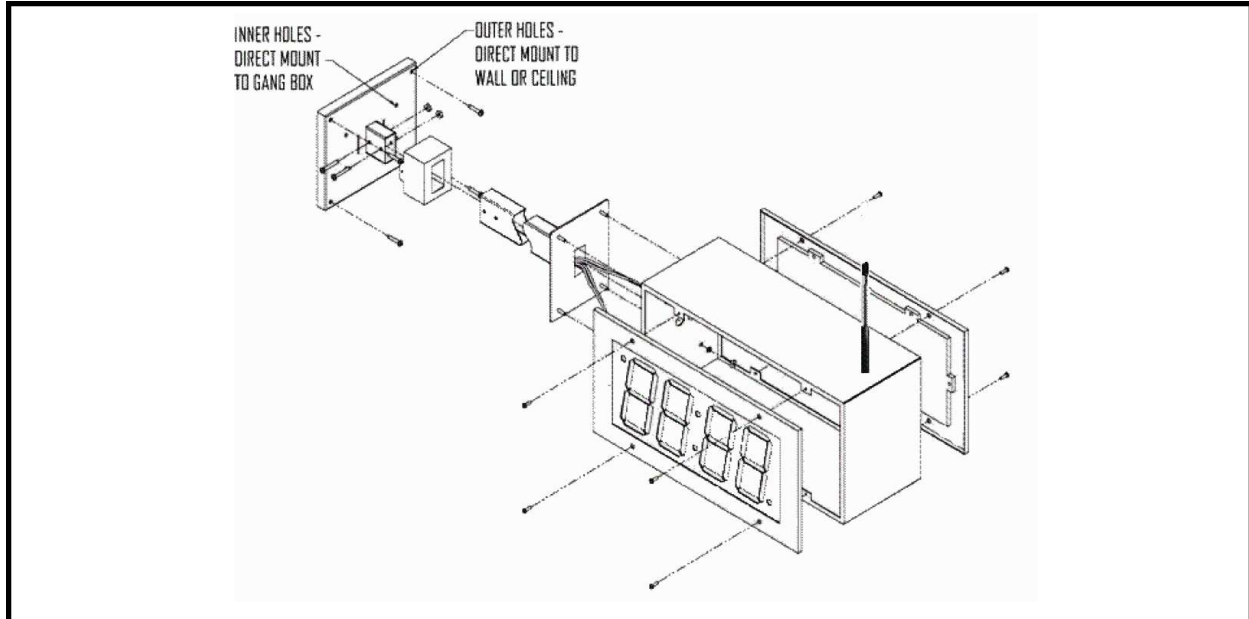

Instructions

1. Screw hanger/mounting rod (included in the kit) into the crossbar (also included in the kit).
2. Insert wires through hanger/mounting rod.
3. Install crossbar using two (2) #6-32 screws into double gang box.
4. Mount the double mount box into the clock base using two (2) #6 nuts and Tooth Lockwasher #6. The double mount can be mounted either on the wall or on the ceiling.
5. Insert the two locking hole plugs (0.187") and the locking hole plug (0.562") into the unused holes.
6. Insert double mount case onto the hanger/mounting rod.
7. Insert the support bracket onto the hanger/mounting rod.
8. Screw the two (2) nuts (included in the kit) onto hanger/mounting rod and secure the clock base to wall.
9. Connect ground wire into double mount box using the tooth lockwasher and machine screw nut (included in the kit).
10. Disconnect the red filter from the display panel.
11. Connect the wiring as shown on the wiring diagram.
12. **IMPORTANT:** If using a low voltage system (24 volt) make sure that the transformer is an **isolated** transformer.
13. Mount the display panel on one (1) side of the double mount box using four (4) black machine screws (#6, included in the kit). Make sure the switches are on the right side.
14. Snap the red filter into the display panel.
15. Repeat steps 9-13 for the second clock.

Wiring Information and Jumper Settings

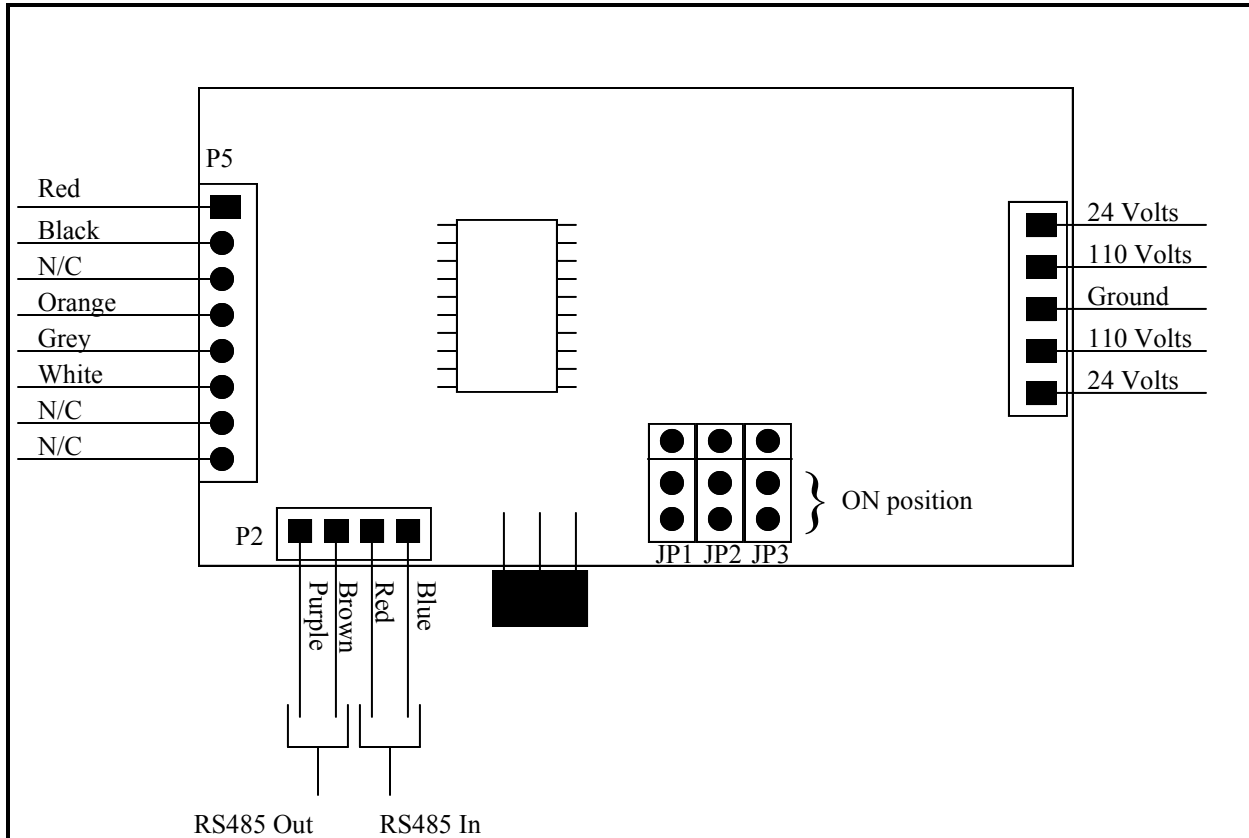

JP1	JP2	JP3
12/24 Hour Mode	Brightness	Loss of Communication Alert
ON: 12 hour mode OFF: 24 hour mode	ON: Brightest OFF: Bright	ON: 5 minutes OFF: 1 hour

Note:

When using the wireless digital clock in a double mount housing, only one clock gets connected to the wireless transceiver through the P5 connector shown above. The clock that is connected to the transceiver will send the time to the second digital clock in the housing through the RS485 data cable (brown & purple wires) shown above on P2. The second clock in the housing will only be connected to power and the RS485 data input cable (red & blue wires)

Frequently Asked Questions

Will the clock cause interference with any of my other wireless devices?

No, the Wireless Digital Clock Series works on 915 - 928 MHz frequency-hopping technology. The clock switches frequencies automatically when the receiver and transmitter are open, thus interference is avoided..

How long does it take for the clock to receive a signal?

Upon power up, the clock will look for the signal for 30 minutes. The Wireless Digital Clock will look for the signal every minute thereafter.

I have double mount clocks and only one clock got the signal.

If only one clock gets the signal check the connection from the two clocks. Only one clock should be connected to the wireless transceiver; the other clock gets the time via the RS485 data cable. Make sure the clock that is connected to the wireless board has the RS485 cable with the purple and brown wires connected to P2, if not flip around the cable.

Do the Wireless Digital Clocks work together with V-AW012 Series analog wireless clocks?

Yes, the Wireless Digital Clocks work integrally with Valcom's V-AW012 Series wireless analog clocks.

How many ways can I mount the Wireless Digital Clock?

The clock can be mounted in either surface or double mount. Please see pages 2 and 3 for more information on mounting instructions.

Can the Wireless Digital Clock be used as an independent clock?

No, the Wireless Digital Clock requires communication input and must be used with either a V-WMC or V-WMCR.

What will happen if the clock is not receiving a signal?

The colon on the display will flash every second.

How can the clock be powered?

The clock is available in 110 volt AC models or in 24 volt AC/DC models.

Troubleshooting

What happens if the clock doesn't power up?

Make sure the wiring is correct. If the clock is 24 volt, the power should be on the orange and yellow wires of the harness. If the clock is 110 volt, the power should be on the black and white wires. The middle wire is ground. If the wiring is correct, take a volt meter and measure the voltage. For 24 volt models, the voltage should be between 14 - 28 volts. For 110 volt models, the voltage should read 85 - 135 volts.

What happens if the clock does not receive the signal?

Take the clock within close proximity to the transmitter and power the clock. If the clock does not correct, call Valcom technical support.

I have a location with a marginal signal. What should I do?

Try to install a repeater, part number V-WMCR in a nearby area to the location or install a 110 volt clock.

FCC Wants You to Know

This equipment has been tested and found to comply with the limits for a Class B digital device, pursuant to Part 15 of the FCC rules. These limits are designed to provide reasonable protection against harmful interference in a commercial installation. This equipment generates, uses and can radiate radio frequency energy and, if not installed and used in accordance with the instructions, may cause harmful interference to radio communications. However, there is no guarantee that interference will not occur in a particular installation. If this equipment does cause harmful interference to radio or television reception, which can be determined by turning the equipment off and on, the user is encouraged to try to correct the interference by one or more of the following measures:

- a) Reorient or relocate the receiving antenna.
- b) Increase the separation between the equipment and receiver.
- c) Connect the equipment to an outlet on a circuit different from which the receiver is connected.
- d) Consult the dealer or an experienced radio/TV technician.

FCC WARNING

Modifications not expressly approved by the manufacturer could void the user authority to operate the equipment under FCC Rules.

Note: For precautionary measures, FCC recommends a distance of 10cm from the clock to constant human physical exposure.