

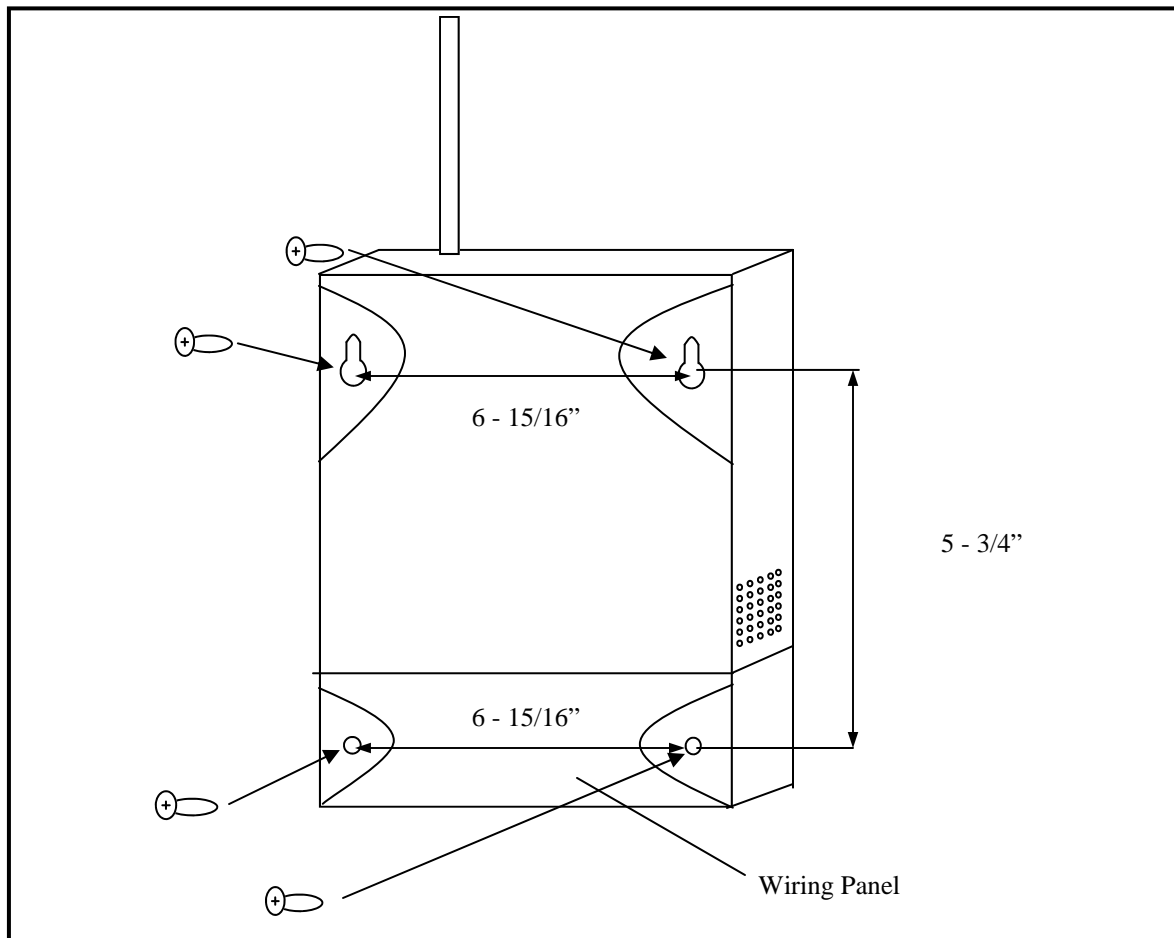

## Table of Contents

<b><u>MOUNTING</u></b>	
Mounting Diagram.....	Page 2
<b><u>WIRING INFORMATION</u></b>	
Wiring Information.....	Page 3
Overhead View.....	Page 4
Setting the V-WMCRA as a Repeater or a Transmitter.....	Page 5
<b><u>FREQUENTLY ASKED QUESTIONS</u></b>	
V-WMCRA Frequently Asked Questions.....	Page 6
<b><u>TROUBLESHOOTING</u></b>	
V-WMCRA Troubleshooting.....	Page 6
<b><u>FCC INFORMATION</u></b>	
FCC Wants You To Know.....	Page 7

## Mounting Diagram



## INSTRUCTIONS

1. Remove the cover of the wiring panel.
2. Mark the four drilling points on the wall based on the drawing above.
3. Drill the holes for the anchors supplied in the mounting kit at the designated markings from step 1.
4. Install the four anchors in the holes that were just drilled.
5. Install the first two screws in the top holes leaving 1/8" of the thread exposed.
6. Line up the top key slots over the screws and lock the master clock into place.
7. Install the bottom screws through the wiring access panel and tighten into place.
8. After all wiring is complete, re-install the wiring panel cover.

## Wiring Information

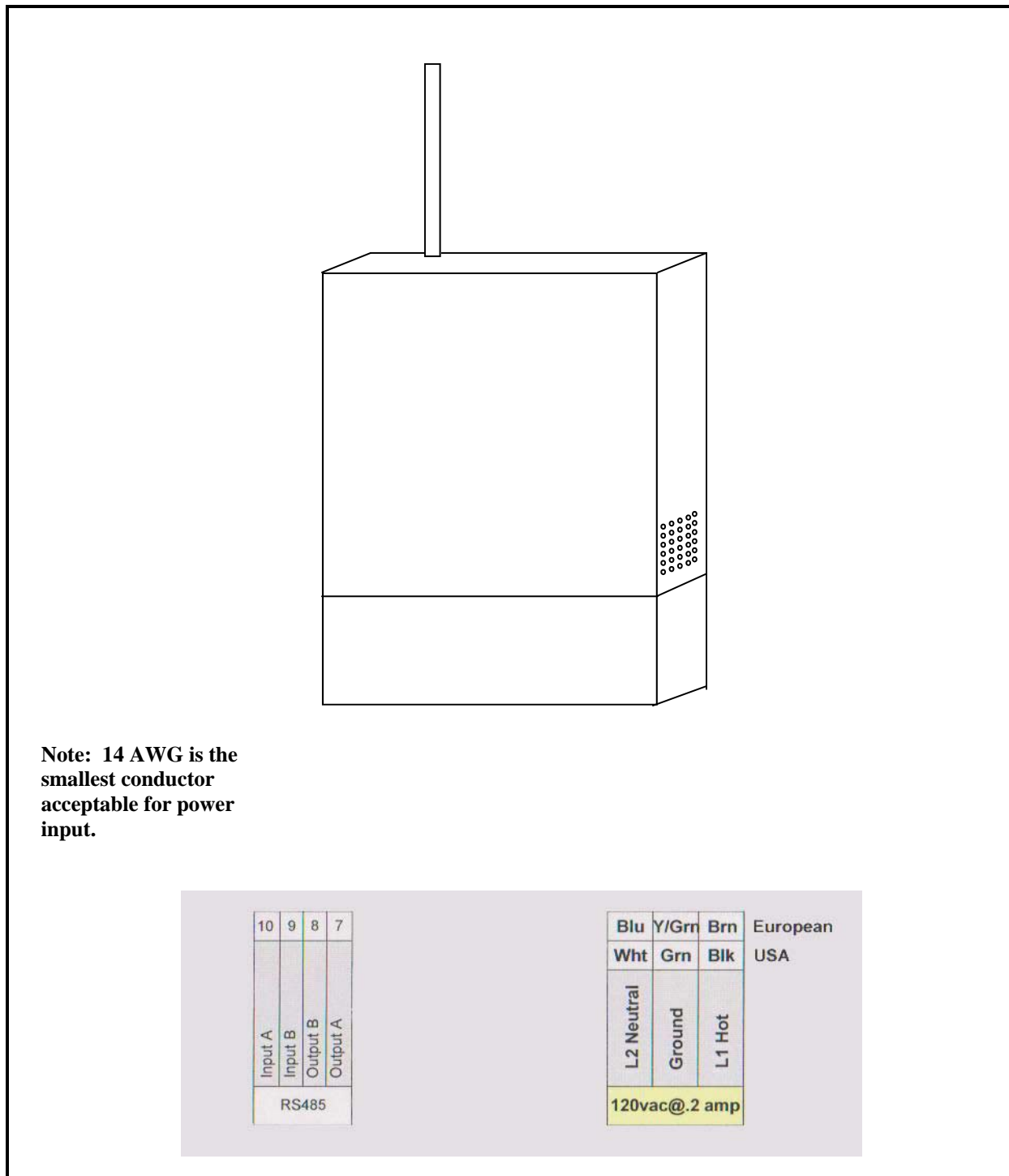

Overhead View

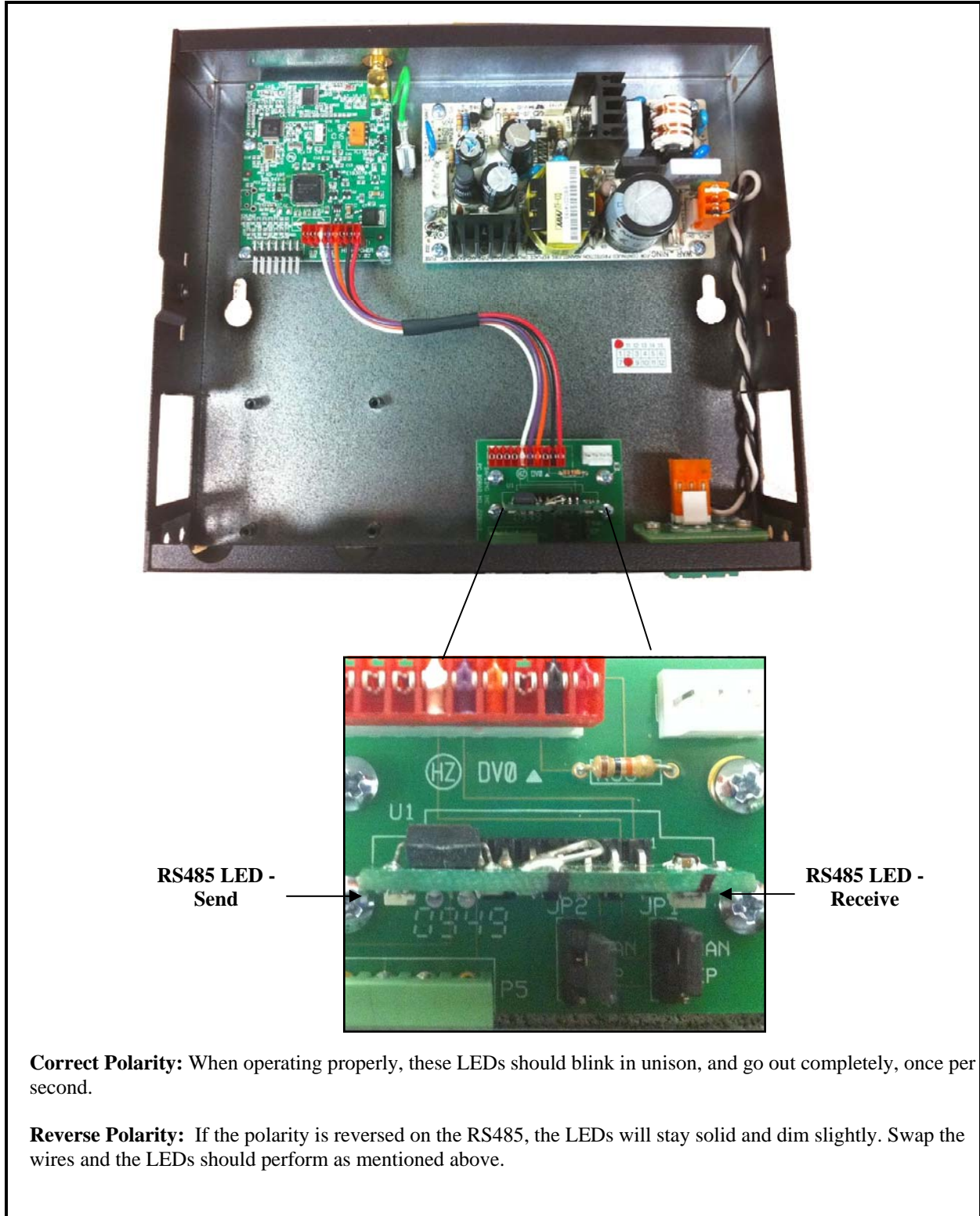

**Correct Polarity:** When operating properly, these LEDs should blink in unison, and go out completely, once per second.

**Reverse Polarity:** If the polarity is reversed on the RS485, the LEDs will stay solid and dim slightly. Swap the wires and the LEDs should perform as mentioned above.

## Jumper Settings for the V-WMCRA as a Repeater or Transmitter

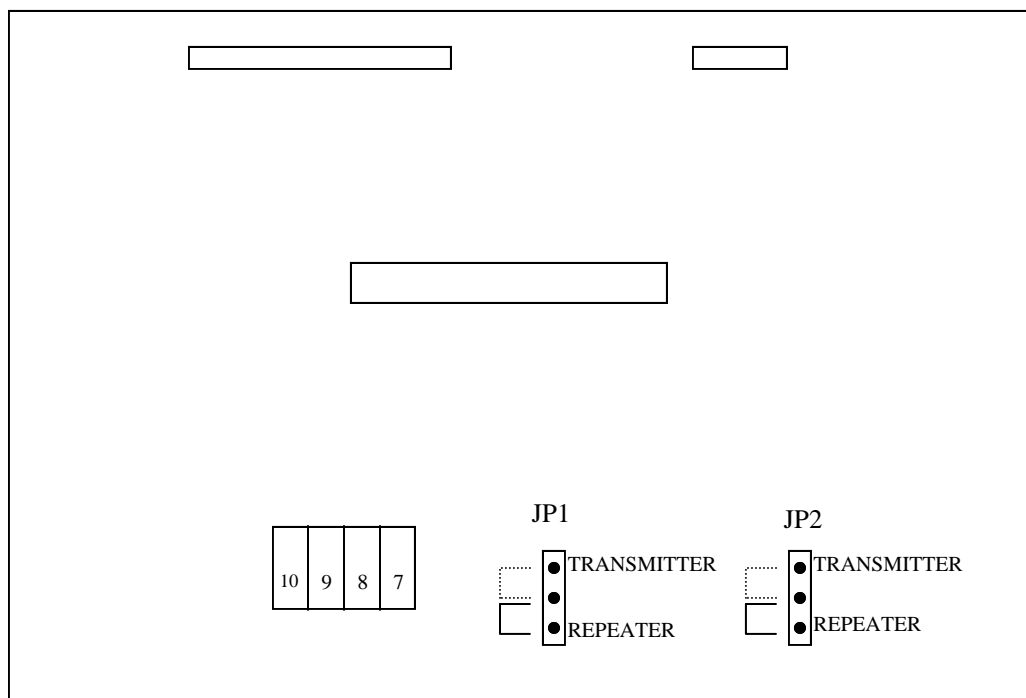

Represents jumpers set as a repeater <sup>1</sup>

Represents jumpers set as a transmitter <sup>1,2</sup>

**Notes:**

- <sup>1</sup> - The Repeater sends out the wireless signal once per minute in repeater mode or transmitter mode.
- <sup>2</sup> - Both JP1 and JP2 should be moved to the transmitter position when the V-WMCRA is receiving clock correction data from a wired source (V-DCPI, V-D11025A, V-D11040A, V-GPS, etc).

## Frequently Asked Questions

### **Where is the best location for the Repeater to be mounted?**

Usually, the hallway is the best location because it is mostly open space in typical applications.

### **How far can the Repeater transmit the wireless signal?**

The Transceiver can transmit up to 2000 meters in open space.

### **Will the Repeater have interference from cordless or cellular phones?**

No, because with Valcom's innovative frequency-hopping technology, interference will not occur. The repeater switches frequencies automatically when the receiver and transmitter is open, thus interference is avoided.

### **Can analog wireless clocks be combined with digital wireless clocks?**

Absolutely. The analog and digital wireless clocks are designed to work together, whether the clocks are running on battery (analog wireless clock only), 24 volts or 110 volts.

### **My power source is 220 volts. Can the Repeater be powered on that voltage?**

Yes, the Repeater can work on 110 volts/50-60 Hz or 220 volts/50-60 Hz.

## Troubleshooting

### **The clocks aren't receiving the signal. What should I do?**

Make sure that the Repeater is in a place where the signal can be transmitted in open space.

### **What should I do if the Repeater is not powering up?**

Measure the voltage between pins L1 & L2. The voltmeter should read 85 - 135 VAC between the hot and the neutral.

## FCC Wants You to Know

This equipment has been tested and found to comply with the limits for a Class B digital device, pursuant to Part 15 of the FCC rules. These limits are designed to provide reasonable protection against harmful interference in a commercial installation. This equipment generates, uses and can radiate radio frequency energy and, if not installed and used in accordance with the instructions, may cause harmful interference to radio communications. However, there is no guarantee that interference will not occur in a particular installation. If this equipment does cause harmful interference to radio or television reception, which can be determined by turning the equipment off and on, the user is encouraged to try to correct the interference by one or more of the following measures:

- a) Reorient or relocate the receiving antenna.
- b) Increase the separation between the equipment and receiver.
- c) Connect the equipment to an outlet on a circuit different from which the receiver is connected.
- d) Consult the dealer or an experienced radio/TV technician.

### FCC WARNING

*Modifications not expressly approved by the manufacturer could void the user authority to operate the equipment under FCC Rules.*

Note: For precautionary measures, FCC recommends a distance of 10cm from the clock to constant human physical exposure.